

# **INSTRUCTION FOR USE AND MAINTENANCE**

**HEATING GASTROTAINERS  
& DISPENSERS**



# **Instructions for use and maintenance**

**In compliance with European Directives**

**CE**

The manufacturer assumes no responsibility for any modifications or technical changes in content or data contained in this user guide. This user guide applies to all heating equipment supplied by Gastro Production Ltd.

# Contents

- 1. Introduction ..... 2
  - 1.1 Orientation in the Instructions for Use ..... 2
  - 1.2 Explanation of symbols used in the Instructions for Use ..... 3
- 2. Common provisions ..... 4
  - 2.1 Transport and equipment ..... 4
    - 2.1.1 Transport ..... 4
    - 2.1.2 Unpacking ..... 4
    - 2.1.3 Dismounting and disposal ..... 4
  - 2.2 Test reports, guarantee conditions ..... 5
    - 2.2.1 Testing ..... 5
    - 2.2.2 Warranty ..... 5
  - 2.3 Safety ..... 6
    - 2.3.1 Safety - electrical current ..... 6
    - 2.3.2 Safety - mechanical parts ..... 7
    - 2.3.3 Safety - heat effects ..... 7
    - 2.3.4 Correct use of the appliance ..... 8
- HEATING GASTROTAINERS & DISPENZERS ..... 9
- 3. Technical parameters ..... 9
  - 3.1 Technical description ..... 9
  - 3.2 Dimensions and weight ..... 9
  - 3.3 Nameplates ..... 10
    - 3.4.1 Technical data of heating Gastrotainers ..... 10
    - 3.4.2 Technical data of heating dispensers ..... 10
- 4. Installation and operation ..... 11
  - 4.1 Installation ..... 11
  - 4.2 Electrical connection ..... 11

4.3 Turning on the Equipment.....	11
4.4 Filling the appliance with goods .....	12
4.5 Operation of the appliance .....	12
5.1 Control knob for heating equipments.....	13
5.2 Electronic control unit .....	14
5.2.1 Description and dimensions.....	14
5.2.2 Operating mode – DIXELL .....	15
5.3 Programming mode.....	18
6. Maintenance .....	18
6.1 General safety measures .....	18
6.2 Regular maintenance .....	19
6.2.1 Inspections .....	19
6.2.2 Maintenance .....	21
7. Work prohibited on the appliance .....	22
8. Malfunctions .....	22
9. Inquiries.....	22
Annex 1 .....	23
Heating Dispenser (drop-in) – Technical drawing .....	23
Annex 2 .....	24
Heating Dispenser (trolley) – Technical drawing.....	24
Annex 3 .....	25
Heating Gastrotainer – Technical drawing .....	25

# 1. Introduction

## 1.1 Orientation in the Instructions for Use

- This user guide has been designed so that the users can easily and quickly find the information necessary to manage the operation and maintenance of heating equipment.
- The users should read the entire user guide with utmost attention and make sure they have perfectly understood all information contained in it.
- The user guide also serves for subsequent reference when needed. For this reason this user guide must be always available to the person operating the equipment.
- Searching this user guide is facilitated by the general table of contents, which allows immediately finding a specific location, and also by table of contents at the head of each section.
- In addition, next to some paragraphs, there are signs inserted to emphasize the importance of the information contained in those paragraphs, **which should be read with special attention!**

## 1.2 Explanation of symbols used in the Instructions for Use



**Warning - Danger of electrical injury** - refers to parts, where there is a danger of electrical injury. Read especially carefully.



**Warning - Rotating parts** - refers to parts, where there is a danger from rotating parts.



**Warning – Risk of injury** - refers to parts, where there is a risk of injury while touching the equipment in operation. Read especially carefully.



**Warning - Important** - refers to parts, where danger might occur, or to parts otherwise important. Read especially carefully.



**Do not wash with pressurized water** – it is forbidden to wash a part so indicated with pressurized water for risk of damaging the equipment.



**Forbidden handling procedures** – refers to parts, where there is a risk of damaging the equipment by handling it in a forbidden way.

## 2. Common provisions

### 2.1 Transport and equipment

#### 2.1.1 Transport

The customer is obliged to inspect the completeness and integrity of the package in which the appliance is transported. Any damage during transport should be addressed with the respective carrier. After delivery, the appliance must be moved to the final place of installation in its original package, if possible.

#### 2.1.2 Unpacking

When the appliance is transported to the place of installation, remove all packages.



**Remove all protective films from the outside and inside of the appliance. The consumer is obliged to dispose of all packages in accordance with the applicable regulations in the country of installation!**

#### 2.1.3 Dismounting and disposal

After its life cycle expires, the appliance must be disposed of in accordance with the applicable regulations in the specific country. The appliance contains:

- stainless steel
- ferrous metals - aluminium, copper
- glass
- PVC
- methacrylate (PMMA)
- polystyrene (PS)
- ABS
- Moplen
- Nylon
- polyethylene
- lubricating oil
- cooling gas
- polyurethane
- electric motors
- supply cable, wiring materials

## 2.2 Test reports, guarantee conditions

### 2.2.1 Testing

Each appliance is factory tested in accordance with the applicable laws, technical standards and government regulations. A test report on the tests performed is issued for each appliance and kept in the factory. The appliance is sent to the customer in a ready-to-use condition. This does not apply to appliances built in complex dispensing lines and installed on-site at the customer.

### 2.2.2 Warranty



Thank you for using our products. Our company will adhere to the relevant provisions of our "Terms and Conditions" and provide you with appropriate services upon submission of the invoice. **We offer a 12-month warranty from the date of purchase (invoice issue date).**

**During the warranty period, our company is responsible for free replacement parts and related services if there is a device malfunction or quality issue during proper operation.**



**The free services do not cover the following damages:**

- Failure to provide an invoice or alteration of invoice details.
- Damage caused during transportation (it is necessary to inspect the condition of the goods upon receipt from the carrier), installation, or improper connection and handling.
- Damage to components caused by failure to provide power and voltage according to the specifications in the technical data.
- Damage caused by disassembly of the products, modification, or alteration of mechanical and electrical structures without permission.
- Damage caused by improper operation, cleaning, or maintenance.



- Non-human-caused damages such as damage caused by abnormal voltage, fire, building collapse, lightning, floods, and other natural disasters, as well as damage caused by rats and other pests.
- Failure to follow the operating instructions during use.
- Wearable and consumable parts.



**If the following conditions are not met, the complaint will not be considered:**

**How to proceed with a complaint for the fastest resolution:**

- **Product identification** – by submitting the order, invoice, or inspection label.
- **Description of the defect** – describe as thoroughly as possible why the product is being claimed.
- **Attach photos or video** (used to assess the claim resolution and possibly propose repairs and ensure spare parts needed for the repair).
- **Customer's request** for claim resolution – repair (service) / return, etc.
- **Contact person** and address where the product is located.

## 2.3 Safety

### 2.3.1 Safety - electrical current

The appliance is fitted from the factory with a connecting cable for power supply, ending with an inseparable plug. The plug can be inserted in a socket with the voltage system of 1, N, PE ~ 230 V, 50 Hz (EURO socket with a protective pin, SHUKO socket with safety contacts)



**The plug may only be replaced by a person with qualifications in electrical engineering; the wiring of the applicable may only be interfered with by a person with qualifications in electrical engineering, subject to agreement with the factory! Interference with the wiring is vitally dangerous and may cause electric shock!**



It is prohibited to touch the supply plug, the control panel and other electrical parts with a wet or damp hand and to wash them with pressure water. There is a risk of electric shock!



Prior to any maintenance, it is necessary to remove the plug of the supply cable from the socket and make sure that the appliance is not powered (e.g. by switching on the main switch and checking whether the appliance responds). If the appliance is hardwired to an electric circuit, it is necessary to switch off the respective circuit breaker, test if the appliance is disconnected and secure the circuit breaker, e.g. with a tag containing the text "Work on Equipment".

### 2.3.2 Safety - mechanical parts

When operating the appliance, it is necessary to exercise increased caution, especially in case of the following work:

- When opening and closing the doors of steam tables, cases; the doors are placed on roller hinges and are easily movable, it is necessary to pay increased attention when closing the doors, there is a risk of trapping a limb.
- **When operating a heating appliance with fans: do not touch and do not insert objects through fan covers. The rotating fan blades may cause an injury.**

### 2.3.3 Safety - heat effects



When operating heating appliances, a part of the appliance is heated to a **high temperature** and **there is a risk of burning**.

### **2.3.4 Correct use of the appliance**



- **The appliance is designed for normal use by an adult. It is not designed for rough handling and operation by children! Appliance operators must be thoroughly and demonstrably trained and keep these Instructions for Use at hand.**
- **The appliance must be operated in accordance with the Instructions for Use. The appliance may only be used for its intended purpose.**
- **Do not place the heating appliance next to an appliance that could be damaged due to the generated thermal energy.**
- **Before the appliance is filled with goods, pre-heat it to the selected temperature. (Gastrotainers)**
- **Do not put any food perishable due to high temperature in the heated area.**
- **Keep the heated area clean.**
- **Do not leave the door of the gastrotainer to the heated area open - this would reduce the appliance's performance and life cycle.**
- **Regularly check the appliance and perform maintenance work as per these Instructions for Use.**

# HEATING GASTROTAINERS & DISPENZERS

The appliance is capable of working faultlessly under the following conditions:

- Altitude up to 1,000 m above sea level.
- Ambient temperature at the appliance between 15°C and 25°C.
- Maximum relative humidity 60%.
- The appliance is not placed close to any other appliance that would be harmed by water steam (cooling cases, open cooling tubs, etc.)

## 3. Technical parameters

### 3.1 Technical description

**Heating Gastrotainers** are equipped with wing door, handle and four wheels for easy maneuverability. Gastrotainers are insulated, which helps to keep food inside warmer for longer and ready to serve immediately. Inside, there are shelves inserts that can be adjusted in height as needed. Staff can transport and serve hot meals. These gastrotainers must not be used for other purposes without an express approval of or, if applicable, structural changes made by Gastro Production s.r.o. These boilers are designed to provide the best results if all the instructions contained in this manual are met. To be able to use the gastrotainers optimally and keep them in an excellent condition, we recommend performing regular maintenance work.

**Heating dispensers** are designed for warming plates, which are then ready for serving, and the dishes remain warm longer thanks to the heated plates. The Dispenser - trolley features two stacking compartments, a handle, and wheels for easy handling and moving. Two out of the four wheels are equipped with brakes for increased safety. The version intended for drop-in a worktop comes in two types – with one or two stacking compartments.

### 3.2 Dimensions and weight

The dimensions and weight of the appliance may be found for each type of appliance at [www.gastro.cz](http://www.gastro.cz).

### 3.3 Nameplates

The nameplate is placed inside the appliance, on the right side, and another nameplate is placed on the inside of the control cover.

 <b>gastro.cz</b> <a href="http://www.gastro.cz">www.gastro.cz</a> <small>PRODUCTION</small>		CZ
		CE
No :	<b>H.0001.02.15</b>	Type : 8D303-00
Input P :	0,97 kW	
Voltage system :	1,N,PE ~ 230V,50Hz	
Current load Iv :	4 A	
Weight :	kg	Climatic class "N"

### 3.4.1 Technical data of heating Gastrotainers

<b>Temperature</b>	~ +85°C
<b>Voltage</b>	1, N, PE ~ 230V, 50Hz
<b>Power input</b>	0,42kW
<b>El. consumption</b>	Power on: 2W Power, ventilation: 38W Power, ventilation, heating: 1080W

### 3.4.2 Technical data of heating dispensers

*1x compartment      2x compartments*

<b>Temperature</b>	+30°C ~ +60°C	
<b>Voltage</b>	1, N, PE ~ 230V, 50Hz	
<b>Power input</b>	0,67kW	1,34kW

## 4. Installation and operation

### 4.1 Installation



**Always proceed carefully and slowly when handling the equipment to avoid damage or injury! Consider the weight of the equipment. Ideally, four people are required to handle the equipment. After unpacking, place the equipment in a horizontal position at the designated location.**

### 4.2 Electrical connection

The appliance is fitted from the factory with a connecting cable for power supply, ending with an inseparable plug. The plug can be inserted in a socket with the voltage system of 1, N, PE ~ 230 V, 50 Hz (EURO socket with a protective pin, SHUKO socket with safety contacts). Insert the supply cable plug in the socket. Make sure the plug is accessible to operators. The supply cable must be placed visibly, without any sharp bends. The supply cable must not be placed on sharp edges of steel and other parts.

### 4.3 Turning on the Equipment



**Make sure the ventilator cover is in place inside the gastrotainer. The device must not be turned on without it.** After positioning the equipment, wait at least 30 minutes before turning it on. During the winter months, wait 12 hours at room temperature.

Turn on the equipment by setting the main power switch to **position 1**. **The indicator light should come on.** For setting the temperature of the space on the electronic control unit (gastrotainer) or control knob (dispensers), refer to section **5**.



**CAUTION!** When heating and operating, the gastrotainer must be closed because at temperatures above 70°C, all energy is converted into steam. It is complicated to keep the high temperature of the appliance, there is excessive steam leaking from the gastrotainer and the life cycle of the appliance is reduced.

## **4.4 Filling the appliance with goods**

When the set temperature is reached, you can fill the gastrotainer with goods and put them on shelves or plates into stacking compartment in heating dispensers. Follow the principles of proper use of the appliance in part 2.3.4.

## **4.5 Operation of the appliance**



- **Keep the heating area clean.**
- **Do not leave the gastrotainer opened – it reduces the performance and life cycle of the appliance.**
- **Regularly check the appliance and perform maintenance work as per section 6 of these Instructions for Use.**

## 5.1 Control knob for heating equipments



To control the heating equipments, the rotary knob on the thermostat is used. Using this knob, you can adjust the desired temperature for the respective device according to its markings. Some knobs feature a visual indicator, such as an expanding section at one end, to signify the addition of heat. Additionally, there are knobs with labeled temperatures for precise temperature adjustments.



## 5.2 Electronic control unit

DIXELL is used to control the heating equipments. The manufacturer is not responsible for a failure of the appliance in case of interference with the settings of the electronic control unit. This does not concern the settings permitted in these Instructions for Use.

**For proper cooling function and condensation evaporation from the evaporator tray, product needs to be set to 'stand-by' mode. This can be done as follows:**

- **Press the lower right button to turn the 'stand-by' mode on/off.**
- **Display shows 'OFF' / after turning on, the temperature value (...°C) will appear on the control unit display**

### 5.2.1 Description and dimensions

DIXELLS are electronic thermostats with passive defrosting, fitted with a microprocessor, suitable for cooling applications at normal temperatures. They are also suitable for mounting in a panel and their size is 32x74 mm. They are equipped with one, two or three relay outputs for controlling the compressor, fans, defrosting and lighting. Up to three PTC or NTC sensors can be connected to them.

#### **Technical parameters:**

Package: **self-extinguishing plastic ABS.**

Cabinet: **front panel 32x74 mm, depth 60 mm.**

Installation: **in a panel with a cut-out 71x29 mm.**

Front panel coverage: **IP65.**

Connection: **screw-on terminal block for wires up to the diameter of 2.5 mm<sup>2</sup>.**

Supply voltage: **230 V~, ±10%; 50, 60 Hz.**

Input power: **3 VA max.**

Data memory: **EEPROM.**

Working temperature range: **0 to 60°C.**

Storage temperature range: **-30 to 85°C.**

Relative humidity: **20 to 85%.**



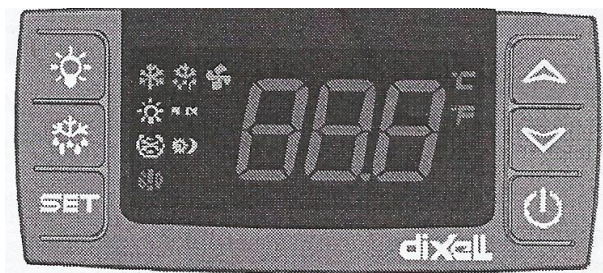

Accuracy: (at an ambient temperature of 25°C): **±0.7°C ± 1 digit.**

## 5.2.2 Operating mode – DIXELL





### FRONT PANEL COMMANDS:



### Button description

<b>SET</b>	<i>Displays the desired value. In programming mode serves for selecting a parameter or confirming an operation.</i>
	<i>(UP): Displays maximum temperature recorded. In programming mode serves for navigating the parameter list and increasing the displayed value.</i>
	<i>(DOWN): Displays minimum temperature recorded. In programming mode serves for navigating the parameter list and decreasing the displayed value.</i>
	<i>Turns the device on and off.</i>
	<i>Turns the lighting on and off, if available.</i>
	<i>(DEF): Not applicable.</i>

### Key combinations

 	<i>Locks and unlocks the keyboard.</i>
<b>SET</b> 	<i>Enters the programming mode.</i>
<b>SET</b> 	<i>Returns to displaying the value of the refrigerated space temperature.</i>

### **Explanation of indicator lamps:**





- lit up – heating on.





- lit up – alarm.

### **DISPLAY OF MIN. ACHIEVED TEMPERATURE:**

1. Press the button .
2. The message "Lo" appears on the display, followed by the minimum achieved temperature.
3. By pressing the button  again or waiting for 5 s, the appliance returns to normal mode, i.e. displays the measured temperature.

### **DISPLAY OF MAX. ACHIEVED TEMPERATURE:**

1. Press the button .
2. The message "Hi" appears on the display, followed by the maximum achieved temperature.
3. By pressing the button  again or waiting for 5 s, the appliance returns to normal mode, i.e. displays the measured temperature.

### **DELETION OF THE RECORDED MIN./MAX. TEMPERATURE:**



1. In the MIN./MAX. temperature display mode, press the button **SET** for longer than 3 s before the message "rSt" appears
2. Confirm by pressing **SET**, the message "rSt" starts flashing. The measured temperature is displayed.

## **MAIN FUNCTIONS**



### **DISPLAY OF TEMPERATURE SET POINT:**

1. Press the button **SET** on the display shortly to display the set point.
2. To return to current temperature, press **SET** shortly again or wait for 5 s.



### CHANGE OF TEMPERATURE SET POINT:

1. Press the button **SET** for longer than 2 s.
2. The value of the set point is displayed and the °C indicator lamp starts flashing.
3. The set point can be changed by pressing the button  or  (within 10 s).
4. The new set point can be saved by pressing the button **SET** again or automatically after 10 s.



### KEYBOARD LOCK:

1. Hold the buttons  +  together for at least 3 s.
2. The message "**POF**" appears and the keyboard is locked. Now it is possible to monitor only the setting of the set point or the recorded MIN / MAX temperature.
3. If any key is pressed for longer than 3 s, the message "**POFP**" appears.

### KEYBOARD UNLOCKING:

Hold the buttons  +  together for at least 3 s, the message "**PON**" appears.

### ON/OFF FUNCTION:

The appliance can be switched off by pressing the button . The message "**OFF**" appears on the display. Control is not active in this mode. It can be reactivated by pressing the button  again.

**CAUTION!!! – Loads connected to contacts of the appliance closed in the rest position remain always live even if the appliance is OFF.**

## 5.3 Programming mode.



The programming mode may only be entered by a service organization holding a permit from the factory.

## 6. Maintenance

### 6.1 General safety measures



Study these Instructions for Use thoroughly before the commencement of maintenance work. Comply with the principles of set forth in section **2.3 Safety**.



**Prior to any maintenance, it is necessary to remove the plug of the supply cable from the socket and make sure that the appliance is not powered (e.g. by switching on the main switch and checking whether the appliance responds).**

**If the appliance is hardwired to an electric circuit, it is necessary to switch off the respective circuit breaker, test if the appliance is disconnected and secure the circuit breaker, e.g. with a tag containing the text "Work on Equipment".**

Proceed with caution and without hurry during maintenance work.



- **Pressure water must not be used for washing the appliance, there is a risk of damage to the controls and electronic parts and the subsequent damage to the entire appliance!!!**
- **For the purposes of cleaning, use regular kitchen detergents approved for use with food!!!**

## 6.2 Regular maintenance

### 6.2.1 Inspections

#### 6.2.1.1 Overall view of the product

- Check visually whether the gastrotainer or heating dispenser is not damaged (deformed, perforated, etc.). If it is damaged, it is necessary to contact a service organization.
- If you see any dirt or dust, you can wipe it with a damp cloth, but only after you turn off the gastrotainer or dispenser and let it cool down.
- For the heating dispenser drop-in the worktop, you can access it from the top if side access is not possible, for example, through a cabinet. Further cleaning instructions for the dispenser can be found in section 6.2.1.3
- **Never use on a stainless steel surface: scouring sponges, scrubbing powder, products containing chlorine, steel wool and table salt.**



#### 6.2.1.2 The inside of the gastrotainer

- Visually check for any dirt inside. In case of cleaning the inside of the gastrotainer, make sure it is turned off and cooled down to avoid burning yourself while cleaning.

- After the interior has cooled down, you can use a mild detergent, sulfonated water and a soft cloth for daily cleaning. Always rinse with clean water afterward and dry with a cloth. For thorough cleaning, it is recommended to use a suitable stainless steel cleaner.



### 6.2.1.3 The inside of the dispenser

- Visually check for any dirt inside. In case of cleaning the inside of the gastrotainer, make sure it is turned off and cooled down to avoid burning yourself while cleaning.
- For the dispenser - trolley, the sides can be removed, allowing the interior to be easily cleaned with a damp cloth for daily cleaning. Always use clean water and then wipe dry.
- For the dispenser drop-in the worktop, you can access it from the top. If there is no other access to the dispenser (e.g., through a cabinet) or if the dispenser cannot be easily removed from the worktop, it is necessary to be careful and use a vacuum cleaner to remove dust and dirt from the top where the plates are inserted.

### 6.2.1.4 Fan cover (Gastrotainer)

- **Always make sure the fan cover is in place after cleaning inside of the gastrotainer. The device must not be turned on without it.**

### 6.2.1.5 Hinges (Gastrotainer)

- Check if the wing door can move freely. Also check that all hinges are properly attached and do not show signs of deformation. If the door grinds, replace the door bearings. **Do not lubricate the hinges or sliding surfaces with any petroleum jelly or oils!**

### 6.2.1.6 Sealing surfaces (Gastrotainer)

- Check all rubber sealing on doors, drawers, etc. Replace all damaged sealing.

### 6.2.1.7 Wheels

- Check that the wheels do not bind anywhere and move freely.
- If you see any damage or does not work as it should, it's best to replace them with new ones to avoid an accident.

### 6.2.1.8 Controls

- Check the control knob and the mechanical thermostat for cracks. Replace a defective knob with a new one.

## 6.2.2 Maintenance

### 6.2.2.1 Daily maintenance

- During maintenance work we comply with the principles set forth in section **6.1 General safety measures**.
- When daily operations are over, switch off the appliance. Remove food from the appliance, wash and wipe it dry. Leave the space open to avoid odours inside.
- **With the appliance switched off, perform the inspections set forth in section 6.2.1.1-6.2.1.8.**

### 6.2.2.2 Monthly maintenance

- During maintenance work we comply with the principles set forth in section **6.1 General safety measures**.
- **During monthly maintenance carry out the activities set forth in sections 6.2.1 Inspections and 6.2.2.1 Daily maintenance.**



## 7. Work prohibited on the appliance



- It is prohibited to use the appliance for other than intended purposes!
- It is prohibited to interfere with the electrical connections of the appliance!
- It is prohibited to perform the prohibited work specified in other sections of these Instructions for Use!
- It is prohibited to wash the appliance with pressure water!
- It is prohibited to treat the appliance roughly!
- It is prohibited to operate the appliance without prior training and without these Instructions for Use!

## 8. Malfunctions

If there is any error, do not interfere with the internal parts in any way and call the service.

## 9. Inquiries

If you need help and advice, do not hesitate to contact us, and we will assist you with everything. You can find our contact information on our website [www.gastro.cz](http://www.gastro.cz).

# Annex 1

## Heating Dispenser (drop-in) – Technical drawing

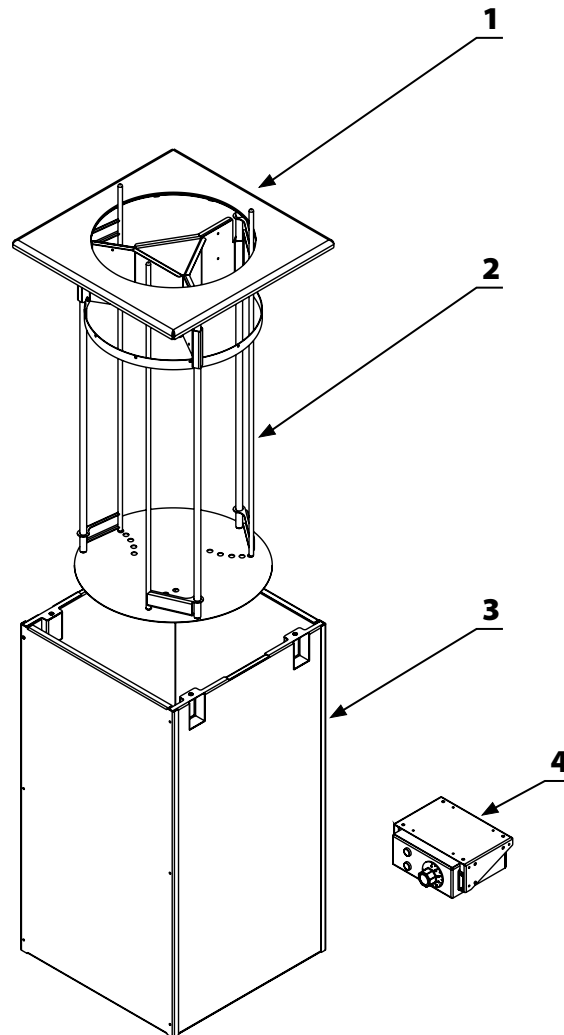

### Legend:

1. Frame (drop-in)
2. Stacking compartment
3. Outer cover
4. Control knob with pilot light

## Annex 2

### Heating Dispenser (trolley) – Technical drawing

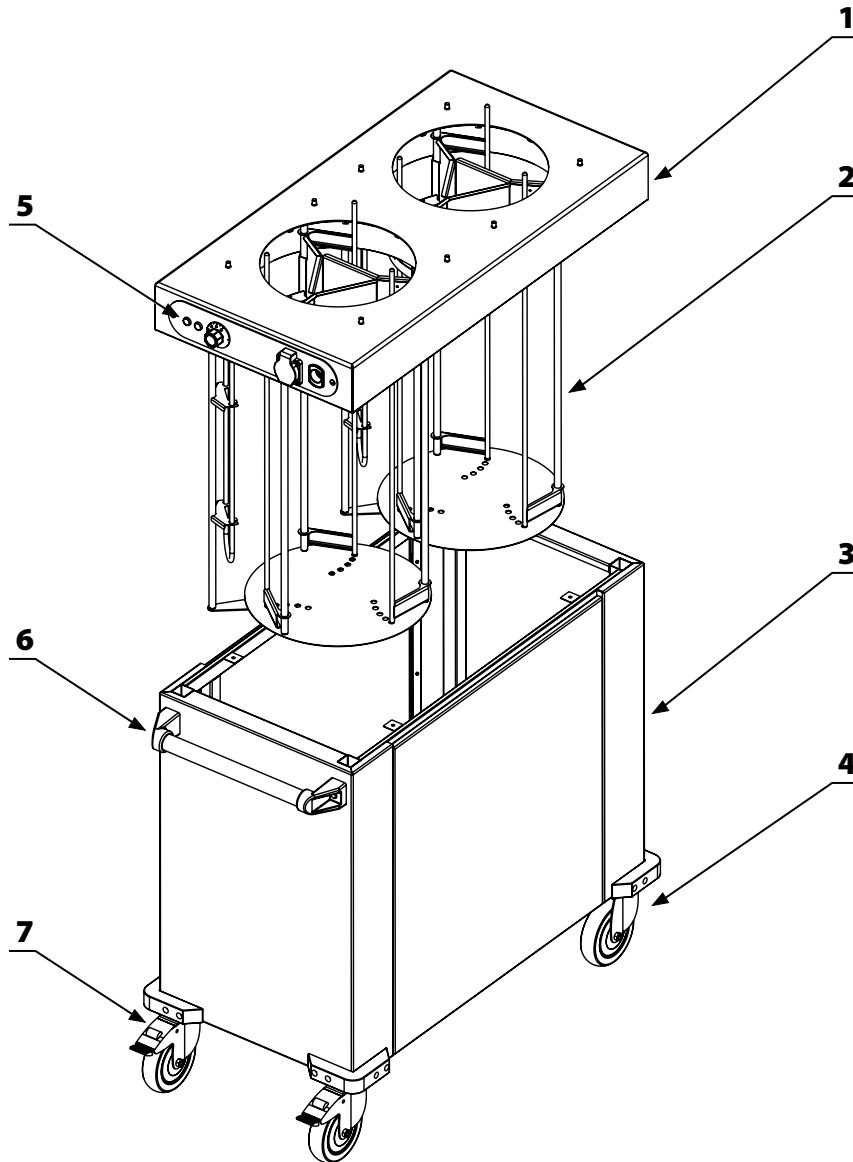

#### Legend:

1. Upper plate
2. Stacking compartments
3. Trolley assembly with removable sides
4. Standard wheels
5. Control panel with control knob, pilot lights and 230V socket with cover
6. Handle
7. Wheels with brakes

## Annex 3

### Heating Gastrotainer – Technical drawing

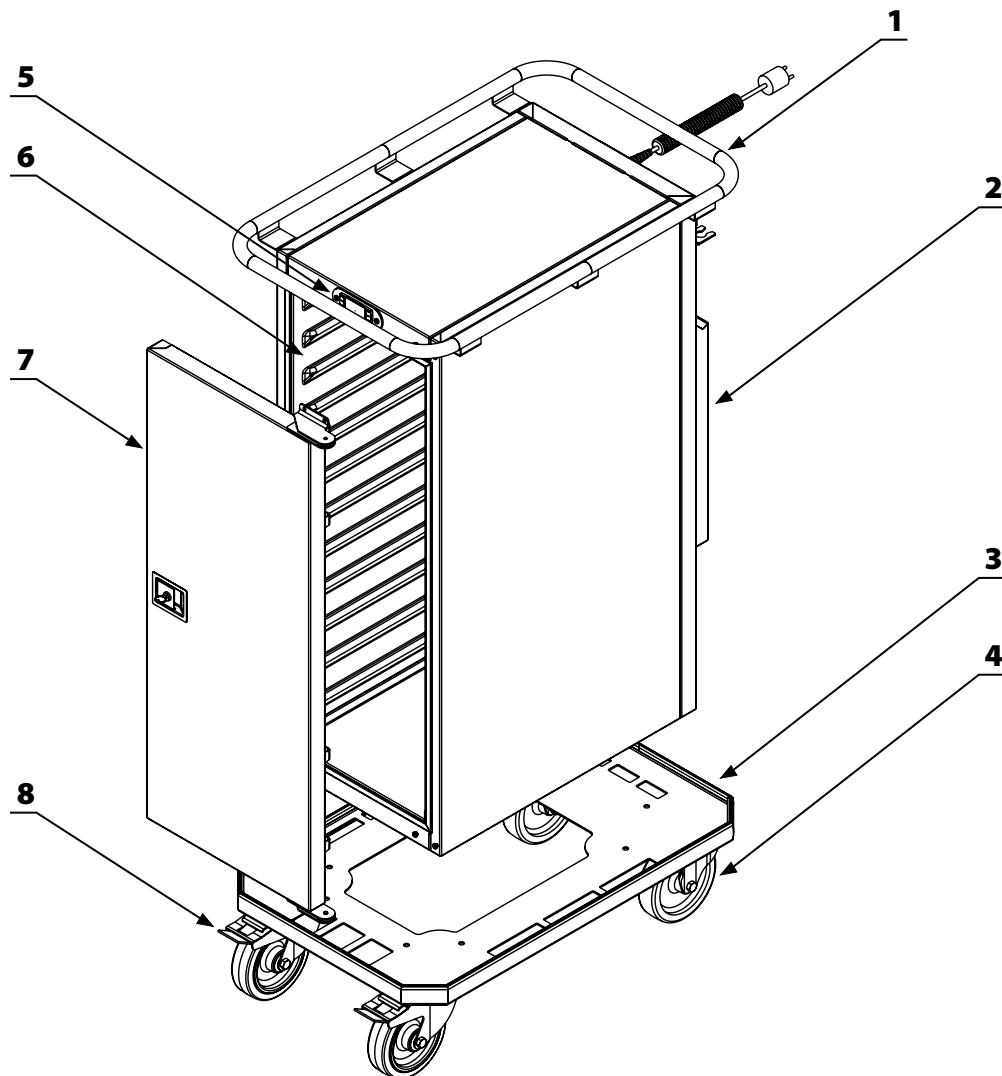

#### Legend:

1. Handle
2. Fan
3. Base of the Gastrotainer
4. Standard wheels
5. Dixell
6. Inserts
7. Wing door
8. Wheels with brakes